

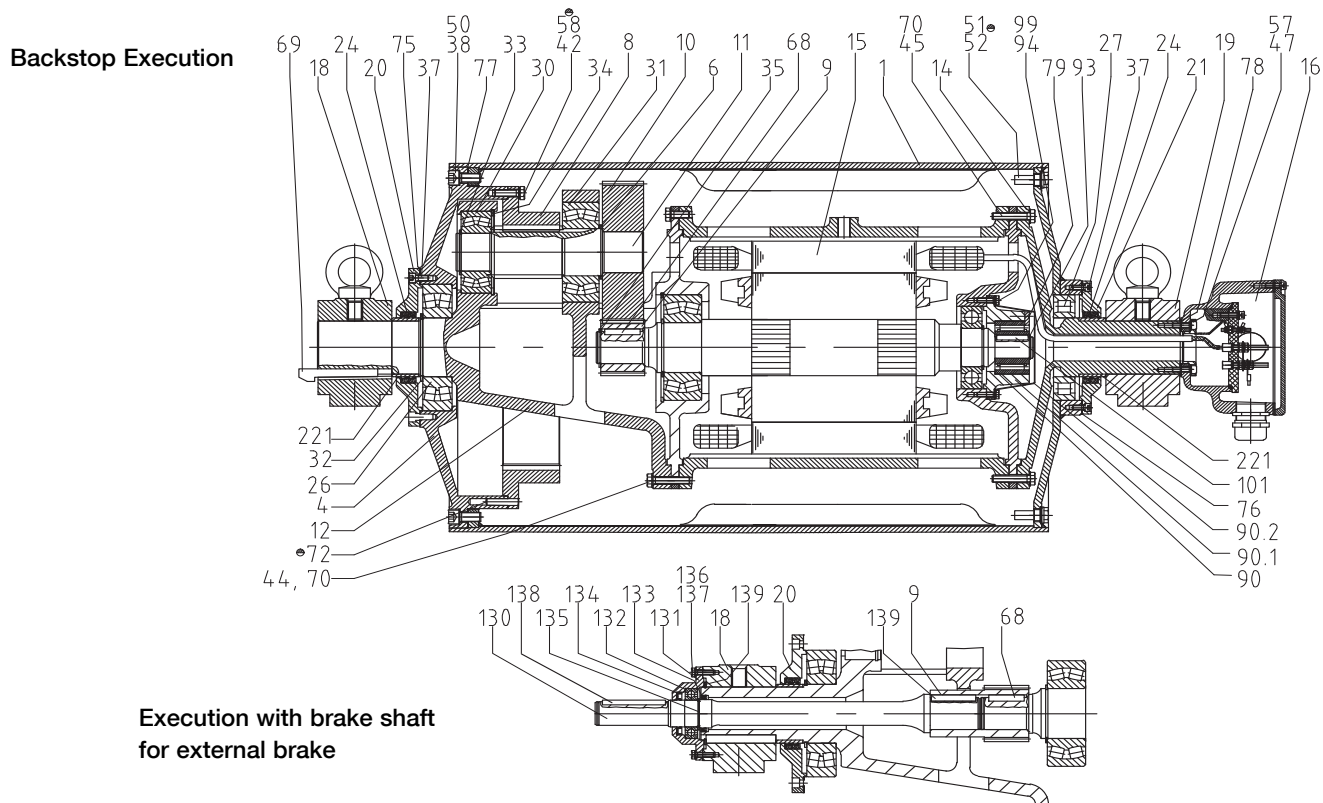

Motorized Pulley 500H – 800H, Ø 500 mm – 800 mm

Spare parts list and sectional drawings

Pos.	Description	Pos.	Description	Pos.	Description
1	Shell	26	Bearing	77	Gasket
4	End housing with geared rim	27	Bearing	78	Gasket
6	Distance washer (630H/800H)	30	Bearing	79	Holding plate
8	Geared rim	31	Bearing	85	Motor flange for backstop/brake
9	Rotor pinion	32	Retaining ring	90	Backstop
10	Input wheel	33	Retaining ring	90.1	Backstop housing
11	Output pinion	34	Retaining ring	90.2	Backstop cover
12	Gear box including rear shaft	35	Retaining ring	93	Retaining ring
13	Rear shaft	37	Hexagon socket screw	94	Hexagon head screw
14	Front shaft	38	Hexagon socket screw	99	Spring washer
15	Stator complete	42	Hexagon head screw	101	Key
15.1	Rotor	44	Hexagon head screw	123	Grease nipple
16	Terminal box complete	45	Hexagon head screw	130	Brake shaft
17	Nipple (for 500H/630M only)	47	Hexagon head screw	131	Mounting bracket bearing cover
18	Mounting brackets rear side (AL)	50	Washer	132	Roller bearing
18.1	Mounting bracket with labyrinth – rear side	51	Gasket	133	Brake shaft seal
19	Mounting bracket front side (ALO)	52	Magnetic oil plug	134	Brake shaft seal
19.1	Mounting brackets with labyrinth – front side	57/58	Spring washer	135	Retaining ring
20	Cover – rear side	68	Key	136	Bolts - bearing cover
20.1	Cover with labyrinth groove	69	Gib key	137	Spring lock washer
21	Cover – front side	70	Waved spring washer	138	Key
21.1	Cover with labyrinth groove	72	Grooved pin	139	Retaining ring
24	2 Dust lip seals each side	73	Set screw	140	Key
		75	Gasket	141	Retaining ring
		76	Gasket	221	Hardened bush





Motorized Pulley 800HD, Ø 800 mm

Spare parts list and sectional drawings

Pos.	Description	Pos.	Description	Pos.	Description
1	Shell	34	Retaining ring	130	Brake shaft
4	End housing with geared rim	35	Retaining ring	131	Mounting bracket bearing cover
6	Distance washer	37	Hexagon socket screw	132	Roller bearing
8	Geared rim	38	Hexagon socket screw	133	Brake shaft seal
9	Rotor pinion	42	Hexagon head screw	134	Brake shaft seal
10	Input wheel	44	Hexagon head screw	135	Retaining ring
11	Output pinion	45	Hexagon head screw	136	Bolts – bearing cover
12	Gear box – cast steel	47	Hexagon head screw	137	Spring lock washer
13	Rear shaft	50	Washer	138	Key
14	Front shaft	51	Gasket	139	Retaining ring
15	Stator complete	52	Magnetic oil plug	140	Key
16	Terminal box complete	58	Spring washer	188	Retaining ring
20	Cover – gear side	68	key	189	Retaining ring
20.1	Cover with labyrinth groove	69	Gib key	190	Retaining ring
21	Cover – front side	70	Waved spring washer	180	Intermediate pinion shaft
21.1	Cover with labyrinth groove	72	Grooved pin	181	Intermediate pinion
24	2 dust lip seals each side	73	Set screw	182	Distance bushing
26	Bearing	75	Gasket	183	Washer
27	Bearing	76	Gasket	184	Roller bearing
28	Bearing	77	Gasket	185	Roller bearing
30	Bearing	78	Gasket	187	Key
31	Bearing	85	motor flange for backstop	191	Retaining ring
32	Retaining ring	90	backstop complete	192	Retaining ring
33	Retaining ring	123	Grease nipple	193	Distance washer
				194	Set screw
				195	Prevailing torque type hexagon nut
				196	Key
				197	Retaining ring
				205	Retaining ring
				206	Retaining ring
				207	Retaining ring
				208	Protective ring
				209	Eye bolt
				210	Washer
				211	Cable gland
				212	Retaining ring
				220	Insulation plate
				221	Hardened bush

Intermediate stage

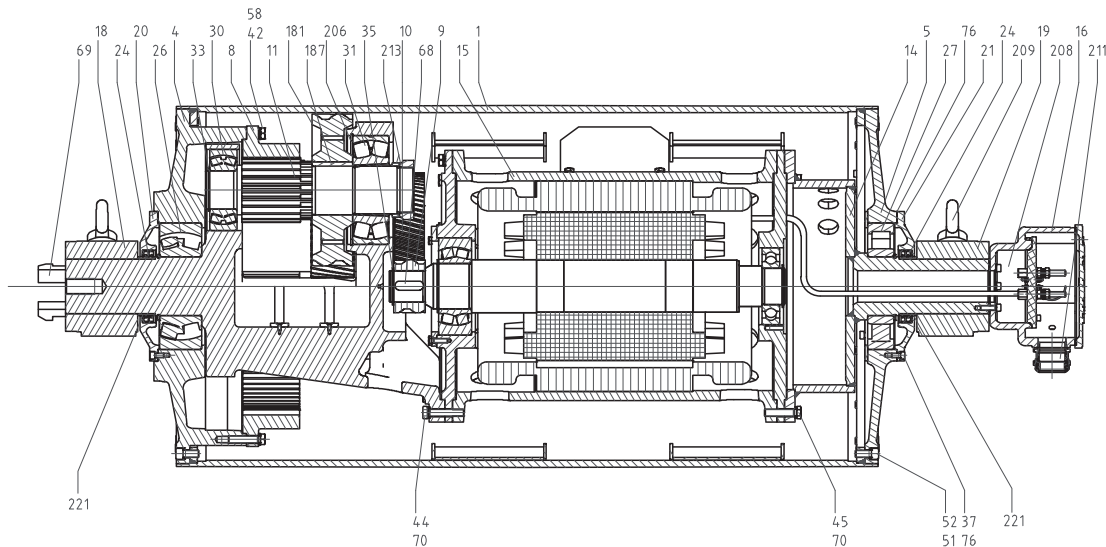
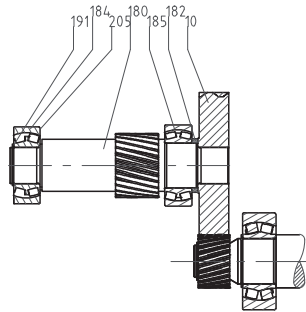



Motorized Pulley 500H - 800HD, Ø500mm - 800mm

Sectional drawings

Backstop Option

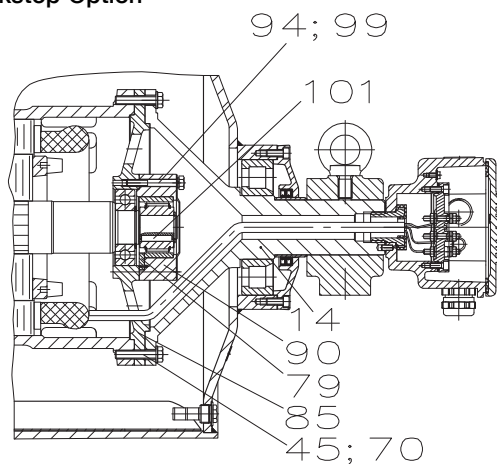

Labyrinth Option

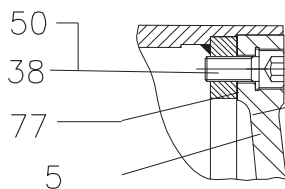
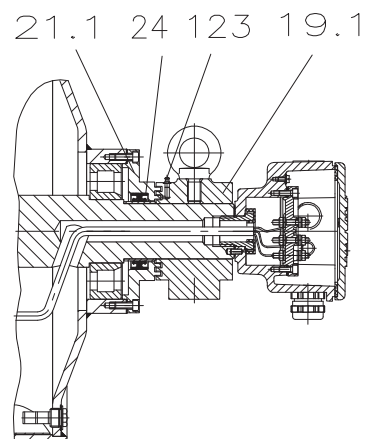

800M-1000HD bolted cast iron end housings at both sides

Terminal box execution for MP type 500H

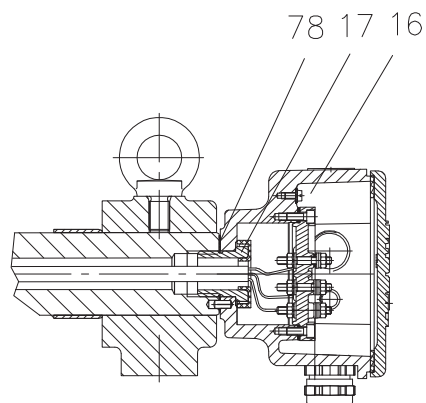

Terminal execution for MP type 630-800HD

